



SIN 242

Issue 2.3
January 2004

Suppliers' Information Note

For The BT Network

CDS™

CALLING LINE IDENTIFICATION SERVICE

PART 1 IDLE STATE, DOWN STREAM SIGNALLING

PART 2 LOOP STATE SIGNALLING

Terminal Equipment Requirements

Each SIN is the copyright of British Telecommunications plc. Reproduction of the SIN is permitted only in its entirety, to disseminate information on the BT Network within your organisation. You must not edit or amend any SIN or reproduce extracts. You must not remove BT trade marks, notices, headings or copyright markings.

This document does not form a part of any contract with BT customers or suppliers.

Users of this document should not rely solely on the information in this document, but should carry out their own tests to satisfy themselves that terminal equipment will work with the BT network.

BT reserves the right to amend or replace any or all of the information in this document.

BT shall have no liability in contract, tort or otherwise for any loss or damage, howsoever arising from use of, or reliance upon, the information in this document by any person.

Due to technological limitations a very small percentage of customer interfaces may not comply with some of the individual characteristics which may be defined in this document.

Publication of this Suppliers' Information Note does not give or imply any licence to any intellectual property rights belonging to British Telecommunications plc or others. It is your sole responsibility to obtain any licences, permissions or consents which may be necessary if you choose to act on the information supplied in the SIN.

Those BT services marked ™ indicates it is a trade mark of British Telecommunications plc.

This SIN is available in Portable Document Format (pdf) from: <http://www.sinet.bt.com/index.htm>

Enquiries relating to this document should be directed to: help@sinet.bt.com

© British Telecommunications plc

Registered Office 81 Newgate Street LONDON EC1A 7AJ
Registered in England no.1800000

CONTENTS

SCOPE	4
GLOSSARY	5
REFERENCES	6
PART 1: IDLE STATE, DOWN STREAM SIGNALLING	7
1 NETWORK CONNECTION	7
1.1 IDLE STATE	7
1.1.1 DC Characteristics, Polarity	7
1.1.2 DC Characteristics, Insulation Resistance, TE in quiescent condition	7
1.1.3 Ringing Signal Characteristics	7
1.1.4 Input impedance of TE in quiescent condition	7
1.1.5 Noise level.....	7
2 SIGNALLING	7
2.1 PHYSICAL LAYER.....	7
2.1.1 Line Reversals.....	10
2.1.2 Silent Periods.....	10
2.1.3 Idle State Tone Alert Signal	10
2.2 DATALINK LAYER.....	12
2.2.1 Channel Seizure	12
2.2.2 Mark.....	12
2.2.3 Checksum.....	12
3 TE OPERATION	13
3.1 APPLICATION OF TE LOADS	13
3.1.1 DC Wetting Pulse	13
3.1.2 AC Load	13
3.1.3 DC Load	14
3.2 DETECTION OF END OF SIGNALLING AND REMOVAL OF LOADS.....	14
3.3 DATA RECEPTION.....	14
3.4 BELL TINKLE	15
3.5 USER INFORMATION.....	15
4 IDLE STATE ELECTRICAL AND SIGNALLING TESTS	15
4.1 PHYSICAL LAYER.....	15
4.1.1 Line reversal	15
4.1.2 Silent Periods.....	15
4.1.3 Idle State Tone Alert Signal	16
4.2 DATALINK LAYER.....	16
4.2.1 Channel Seizure	16
4.2.2 Mark Signal	16
4.2.3 Checksum.....	16
4.3 TE OPERATION	17
4.3.1 DC wetting pulse.....	17
4.3.2 AC Load.....	17
4.3.3 DC Load	17
4.3.4 Detection of end of Signalling and removal of Loads.....	18

PART 2: LOOP STATE SIGNALLING	19
1 NETWORK CONNECTION	19
1.1 LOOP STATE	19
2 SIGNALLING	19
2.1 PHYSICAL LAYER	19
2.1.1 <i>The Start Point</i>	21
2.1.2 <i>Loop State Tone Alert Signal</i>	21
2.2 DATALINK LAYER(BASIC MODE)	22
2.2.1 <i>Channel Seizure</i>	22
2.2.2 <i>Mark Signal</i>	22
2.2.3 <i>Checksum</i>	22
3 TE OPERATION	23
3.1 DETECTION OF ALERT SIGNAL	23
3.2 ANALYSIS OF ALERT SIGNAL	23
3.3 ACKNOWLEDGE SIGNAL (ACK)	23
3.4 DETECTION OF MESSAGE	24
3.5 USER INFORMATION	24
4 LOOP STATE ELECTRICAL AND SIGNALLING TESTS	25
4.1 TIMING, ACK AND MUTING	25
4.2 DATALINK LAYER	25
4.3 DETECTION OF OTHER TE IN THE LOOP STATE	26
HISTORY	26
ANNEX A CALLING LINE IDENTIFICATION PRESENTATION (CLIP)	27
A1 VALID CLIP MESSAGE	27
A1.1 MESSAGE TYPE	27
A1.2 MESSAGE LENGTH	28
A1.3 CALL TYPE	28
A1.4 TIME & DATE	28
A1.5 CALLING LINE DIRECTORY NUMBER	28
A1.6 REASON FOR ABSENCE OF CALLING LINE NUMBER (DN)	29
A1.7 CALLED DIRECTORY NUMBER	29
A1.8 CALLER NAME/TEXT	29
A1.9 REASON FOR ABSENCE OF CALLER NAME	29
A1.10 NETWORK MESSAGE SYSTEM STATUS	30
A1.11 CLIP MESSAGE ENCODING	30
ANNEX B CALLING LINE IDENTITY PRESENTATION WITH CALL WAITING	33
B1 OVERVIEW	33
B2 MESSAGE FORMAT	34
B3 CLIP+CW MESSAGE TIMING	34
B4 REQUIREMENTS FOR CLIP PARAMETERS	34
B5 MESSAGE LENGTH	34
B6 MESSAGE STRUCTURE EXAMPLE	34

Scope

This document describes requirements for Terminal Equipment (TE) intended to operate with BT's **CDS™** Calling Line Identification (CLI) Service. This service is described in Suppliers' Information Note 227 ^[1] (SIN227).

PART 1 applies to TE designed to receive Idle State, Down Stream signalling to provide facilities described in Annexes to this document.

PART 2 applies to TE designed to receive Loop State signalling to provide facilities described in Annexes to this document.

Annex A - This part covers Calling Line Identification Presentation (CLIP) as described in SIN227 Annex A.

Annex B - This part covers Calling Line Identity Presentation (CLIP) combined with Call Waiting (CW) as described in SIN227 Annex B.

DESIGN GUIDANCE

Part 1, Section 2 of this document describes the values of CLI signals in the Idle State which a terminal should be designed to receive.

Part 1, Section 3 describes the way in which the TE should respond to signals in the Idle State.

Part 1, Section 4 contains conformance tests which the TE must meet to ensure reliable operation in the Idle State.

Part 2, Section 2 describes the values of CLI signals in the Loop State which a terminal should be designed to receive.

Part 2, Section 3 describes the way in which the TE should respond to signals in the Loop State.

Part 2, Section 4 contains conformance tests which the TE must meet to ensure reliable operation in the Loop State.

CDS™ TRADE MARK

The **CDS™** trade mark logo has been developed in order to enable customers to identify TE which has been tested in accordance with the appropriate requirements of SIN 242 and confirmed as fully compliant, and which is manufactured subject to appropriate standards of quality assurance.

To obtain a licence to display the CDS™ logo TE must meet the requirements of Part 1, Section 4, Idle State Electrical And Signalling Tests.

The **CDS™** logo will be promoted for this purpose and is to be reproduced as laid down in the accompanying "**CDS™ - Caller Display Logo Guidelines**". A copy of the *Logo Guidelines* may be requested from: help@sinet.bt.com

Licences to use the **CDS™** logo will be granted subject to confirmation that the specified TE has been tested as fully compliant with the relevant parts of SIN242 and that manufacture is undertaken with appropriate standards of quality assurance.

ANYONE WISHING TO USE THE **CDS™** LOGO MUST OBTAIN A LICENCE BEFORE DOING SO.

For information on where to apply for a copy of the **CDS™** trade mark logo licence terms please see the contact information at <http://www.sinet.bt.com/usenum.htm>.

Glossary

ACK	Acknowledgement
CLI	Calling Line Identification
CLIP	Calling Line Identification Presentation
CW	Call Waiting
Down Stream	The direction of signals from Network to TE
DTMF	Dual Tone Multi Frequency
FSK	Frequency Shift Keying
Idle State	An electrical condition into which the TE is placed, when connected to the network, such that it draws minimum current and does not activate the exchange (ETS 300 001:1992 para 1.4.5.1) ⁱ
Loop State	An electrical condition into which the TE is placed, when connected to the network, such that it draws enough current to be capable of activating the exchange (ETS 300 001:1992 para 1.4.5.2)
SIN	Suppliers' Information Note
TE	Terminal Equipment

ⁱ The TE states described in ETS 300 001:1992 do not fully cover the conditions established by BT's **CDS™** Calling Line Identification Service, however the differences are fully described in this document.

References

[1]	SIN 227	CDS™ Calling Line Identification Service - Service Description
[2]	ETSI Rec. ETS 300 001	Attachments to the Public Switched Telephone Network (PSTN); General technical requirements for equipment connected to an analogue subscriber interface in the PSTN
[3]	ITU-T Rec. V.23	600/1200-baud modem standardized for use in the general switched telephone network
[4]	BABT Doc. NV NTR Issue 2	UK Non-Voice National Technical Requirement
[5]	SIN 351	BT Public Switched Telephone Network (PSTN): Technical Characteristics Of The Analogue Line Interface
[6]	Bellcore Doc. SR-TSV-002476	Considerations For Voiceband Data Transmission Interfaces
[7]	Bellcore Report SR-3004 Issue 2	Issue 2, Testing Guidelines for Analog Type 1, 2 and 3 CPE as described in SR-INS-002726
[8]	BS6305:1992	General requirements for connection to public switched telephone networks run by certain public telecommunications operators
[9]	ITU-T Rec. Q.23	Technical features of push-button telephone sets

For further information or copies of referenced sources, please see document sources at <http://www.sinet.bt.com/usenum.htm#docsources>

PART 1: IDLE STATE, DOWN STREAM SIGNALLING

1 Network Connection

1.1 Idle State

Before the receipt of CLI signals, the TE shall present a quiescent or idle state as described in ETS 300 001:1992 ^[2] clause 1.4.5.1. and meet the requirements of ETS 300 001:1992 as follows:

1.1.1 DC Characteristics, Polarity

ETS 300 001:1992 clause 3.1

1.1.2 DC Characteristics, Insulation Resistance, TE in quiescent condition

ETS 300 001:1992 clause 2.2.1

1.1.3 Ringing Signal Characteristics

ETS 300 001:1992 clauses 3

1.1.4 Input impedance of TE in quiescent condition

ETS 300 001:1992 clause 4.1.1

1.1.5 Noise level

ETS 300 001:1992 clause 4.5

2 Signalling

2.1 Physical Layer

The TE shall detect CLI signals and operate as shown in Fig 1- 1. and Table 1- 1.

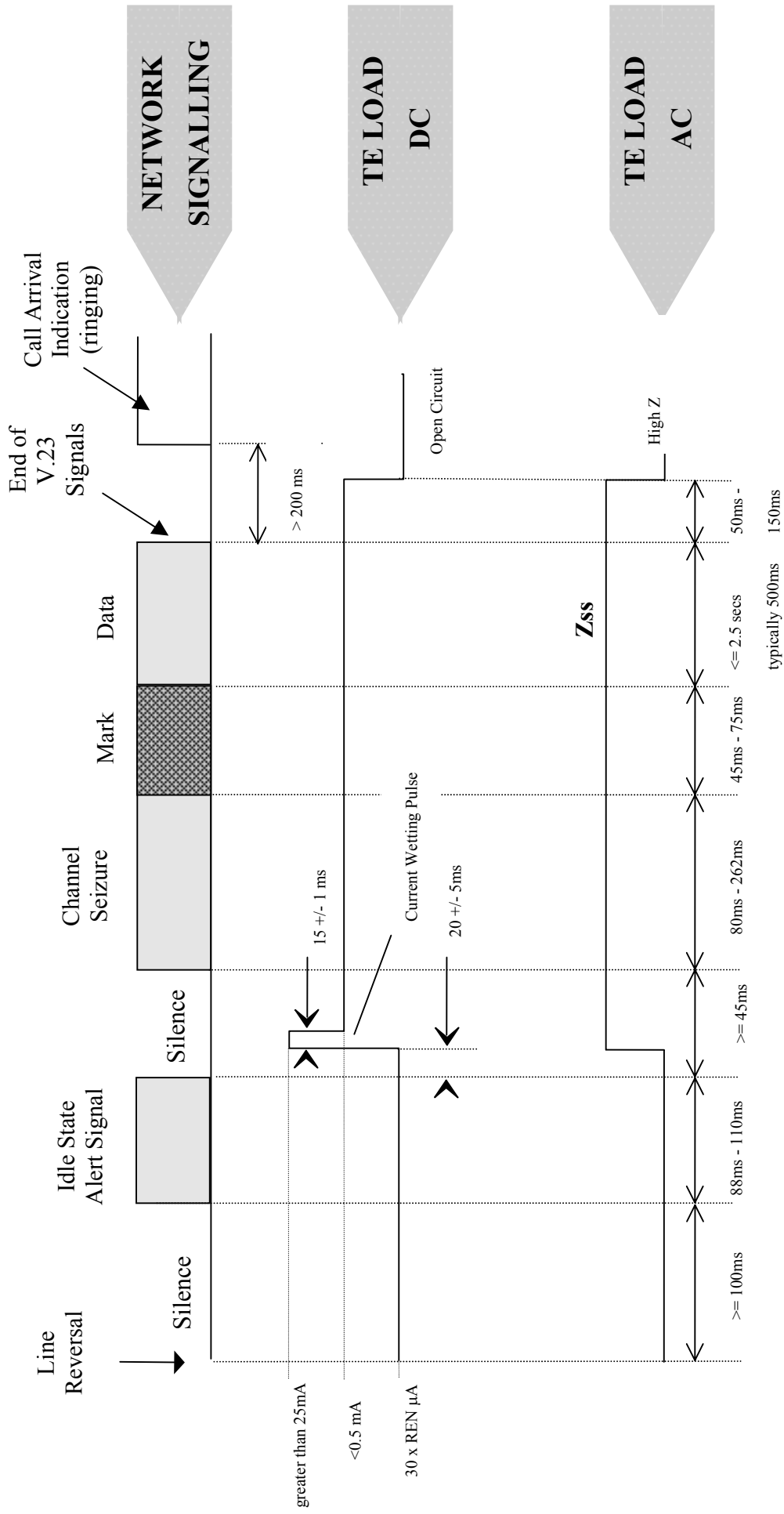

Fig 1-1. CLI Idle State, Down Stream signalling. Sequence of events.

Network	TE	reference
reverse polarity	detect reverse polarity	2.1.1
apply first silent period	detect first silent period	2.1.2
send on-hook tone alert signal	detect on-hook tone alert signal	2.1.3
apply second silent period	detect second silent period	2.1.2
	apply DC wetting pulse	3.1.1
	apply AC load	3.1.2
	apply DC load	3.1.3
send channel seizure	detect channel seizure	2.2.1
send mark	detect mark	2.2.2
send data	receive data	3.3
data ends		
	remove all loads	3.2
send call arrival indication		

Table 1- 1. CLI Idle State, Down Stream signalling. Sequence of events.

2.1.1 Line Reversals

The TE shall detect the polarity reversal at the start of the CLI signalling.

The potential difference, measured at the TE connection to line, between the two wires of the exchange line may be reversed in polarity as shown in Table 1- 2.

Case	reversal	values	slew
1	from + ve to - ve	15V	30ms
2	from - ve to + ve	15V	30ms
3	from + ve to - ve	50V	1ms
4	from - ve to + ve	50v	1ms
5	from + ve to - ve	70v	500µs
6	from - ve to + ve	70V	500µs

Table 1- 2. Line reversal

Compliance shall be checked by inspection and appropriate functional test in accordance with 4.1.1.

2.1.2 Silent Periods

The TE shall detect the silent period directly following the Line Reversal (silence period 1) and the silent period directly following the Idle State Tone Alert Signal (silence period 2)

The silent periods may vary within the times shown in Table 1- 3.

Case	period 1	period 2
1	100ms	45ms
2	100ms	4.8s
3	4.8s	45ms

Table 1- 3. Silent Periods

Compliance shall be checked by inspection and appropriate functional test in accordance with 4.1.2.

2.1.3 Idle State Tone Alert Signal

TE must recognise the Idle State Tone Alert Signal.

TE may recognise the Idle State Tone Alert Signal by detection of a single signal frequency or by the detection of both frequencies together. In the case of single frequency detection the recognition time should be not less than 30 ms. If both frequencies are detected the recognition time can be reduced to not less than 20 ms.

Idle State Tone Alert Signal may vary within the valid limits shown in Table 1- 4a. and 1- 4b.

SINGLE TONE DETECTION

frequency Hz	level ⁱⁱ	duration	validity
2150 or 2780	-2.2 dBV	28 ms	NOT valid
2110 or 2720	-2.2 dBV	88 ms	valid
2150 or 2780	-2.2 dBV	110 ms	valid
2150 or 2780	-40 dBV	28 ms	NOT valid
2110 or 2720	-40 dBV	88 ms	valid
2150 or 2780	-40 dBV	110 ms	valid
2130 or 2750	-46 dBV	110 ms	NOT valid
2130 +/- 75	-2.2 dBV	110 ms	NOT valid
2750 +/- 95	-2.2 dBV	110 ms	NOT valid

Table 1- 4a. Idle State Tone Alert - Single Tone Detection

DUAL TONE DETECTION

frequency Hz	level ⁱⁱ (total)	twist ⁱⁱⁱ	duration	validity
2130 and 2750	-2.2 dBV	0dB	19 ms	NOT valid
2110 and 2745	-2.2 dBV	7dB	88 ms	valid
2150 and 2780	-2.2 dBV	7dB	110 ms	valid
2130 and 2750	-40 dBV	0dB	19 ms	NOT valid
2110 and 2745	-40 dBV	7dB	88 ms	valid
2150 and 2780	-40 dBV	7dB	110 ms	valid
2130 and 2750	-46 dBV	0dB	110 ms	NOT valid
2130 +/- 75 and 2750 +/- 95	-2.2 dBV	0dB	110 ms	NOT valid

Table 1- 4b. Idle State Tone Alert Signal - Dual Tone Detection

Compliance shall be checked by inspection and appropriate functional test in accordance with 4.1.3.

ⁱⁱ noise may be present at a level of 20 dB below signal level during any of these cases.

ⁱⁱⁱ twist may be in either direction

2.2 Datalink Layer

TE shall recognise ITU-T Recommendation V.23 ^[3] FSK signalling.

The received V.23 FSK signalling may vary between the values shown in Table 1- 5.

Mark (logic 1)frequency	1280.5 Hz	1319.5 Hz
Space (logic 0)frequency	2069.5 Hz	2131.5 Hz
Mark level	-40dBV	-14 dBV
Space level	-36 dBV	-8 dBV
Total power of extraneous signals in the voice band (300-3400 Hz).	-64 dBV	-34 dBV
Transmission rate	1188 baud	1212 baud

Table 1- 5. Received Characteristics of V.23 Signals

2.2.1 Channel Seizure

The TE shall detect the Channel Seizure Signal.

The Channel Seizure may vary between 96 bits and 315 bits.

Compliance shall be checked by inspection and appropriate functional test in accordance with 4.2.1.

2.2.2 Mark

The TE shall detect the Mark signal.

Compliance shall be checked by inspection and appropriate functional test in accordance with 4.2.2.

2.2.3 Checksum

TE shall always check the checksum byte. If the checksum is in error, then the signalling packet shall be treated as erroneous in its entirety and discarded. The TE shall not assume even that the message type byte is correct, and so NO assumption can be made as to the purpose of the message.

Compliance shall be checked by inspection and appropriate functional test in accordance with 4.2.3.

Note. If the Checksum is in error it may be useful to display a suitable message.

3 TE Operation

The TE shall operate in the following way.

3.1 Application Of TE Loads

The TE shall apply AC and DC loads as shown in Fig 1- 1. and described below.

3.1.1 DC Wetting Pulse

The TE shall draw a pulse of current from the line. This shall be by applying a resistive load for 15 ± 1 ms. It shall be applied 20 ± 5 ms after the end of the Idle State Tone Alert Signal.

Conformance shall be checked by test, in accordance with 4.3.1.

3.1.2 AC Load

The TE shall apply an AC load between the 'a' and 'b' wires within 1 ms of the application of the DC wetting pulse.

The return loss shall not be less than:

(a) the values shown in Table 1- 6 with respect to the reference network, Z_{SS} , (reference 3) in Fig 1- 2. and

(b) 7 dB in the frequency range 200 Hz to 4000 Hz with respect to the network shown in Figure 4.1.2(GB)1 of ETS300 001: 1992.

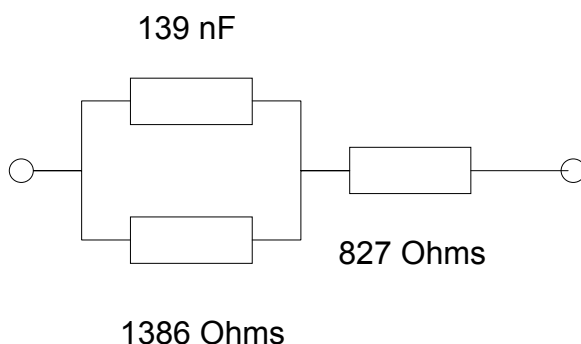

Fig 1- 2. Z_{SS}

Frequency (Hz)	Return Loss (dB)	Frequency (Hz)	Return Loss (dB)
200	12	1250	25
300	16	1600	25
400	18	2000	25
500	21	2500	25
600	22	3000	25
800	25	3500	25
1000	25	4000	25

Table 1- 6. Return loss values

Compliance shall be checked by inspection and appropriate functional test in accordance with 4.3.2.

3.1.3 DC Load

As an option the TE may apply a load to draw DC. up to 0.5 mA. The DC load shall be applied and removed at the same time as the AC load impedance.

Compliance shall be checked by inspection and appropriate functional test in accordance with 4.3.3.

3.2 Detection Of End Of Signalling And Removal Of Loads

The TE must be able to detect the presence or absence of V.23 signalling (the presence of the Mark and Space signals), and must remove both AC and DC loads and revert to Idle State within a period 100 ± 50 msec after the end of V.23 signalling for a complete message.

Note: It is very important that the TE does not remove the AC and DC loads until the end of the V.23 signalling even if the message is detected as invalid or incorrect. This is because voltage transients introduced by removal of the loads may corrupt the signalling received by other CDS™ TE on the same line.

The TE may not always be able to interpret the V.23 message, so it is NOT sufficient to try to detect the end of message by looking at the data.

Compliance shall be checked by inspection and appropriate functional test in accordance with 4.3.4.

3.3 Data Reception

TE shall receive data and operate as described in appropriate Annexes to this document.

3.4 Bell Tinkle

It is recommended that TE also apply a 100 Ω shunt between the A wire and the bell wire for a period lasting from 10 ms before the start, until 10 ms after the end of the Wetting Current Pulse.

This shunt is identical to the shunt applied during dialling, and is to prevent bell tinkle.

3.5 User Information

In addition to the user information called up by other standards, there shall be advice about multiple installation of TE and interpretation of error messages.

Where TE is designed to work with Caller Display in the Idle State only (Part 1 of this SIN) and not in the Loop Sate (Part 2) the user information should make this clear in a prominent position.

4 Idle State Electrical And Signalling Tests

Valid CLI test messages, providing facilities described in Annexes to SIN227 and of types which the TE is designed to receive, shall be sent to the TE with each of the conditions of 4.1 to 4.3 applied. In each case only the parameter concerned shall be varied with all other parameters set to centre (nominal) specification unless stated otherwise. The signalling sequence and parameters are shown in Fig 1- 1. and Table 1- 1.

TE shall respond to valid conditions by operating as described in clause 4.3, TE Operation, and receiving data as described in Annexes to this part.

4.1 Physical Layer

4.1.1 Line reversal

Using test circuit 1, valid CLI signals are sent to the TE with the polarity reversal set in turn to the values of each case in Table 1- 2.

The TE shall detect the conditions as valid.

4.1.2 Silent Periods

Using test circuit 1, valid CLI signals are sent to the TE with the silent periods set in turn to the values of each case in Table 1- 3.

The TE shall detect the conditions as valid.

4.1.3 Idle State Tone Alert Signal

Using test circuit 1, valid CLI signals are sent to the TE with the idle state tone alert signal set in turn to the values of each case in Table 1- 7a. and 1- 7b.

The TE shall detect the conditions as valid.

SINGLE TONE DETECTION

Case	frequency Hz	level	duration	validity
1	2110 or 2720	-2.2 dBV	90ms	valid
2	2150 or 2780	-2.2 dBV	110 ms	valid
3	2110 or 2720	-40 dBV	90 ms	valid
4	2150 or 2780	-40 dBV	110 ms	valid

Table 1- 7a. Idle State Tone Alert - Single Tone Detection

DUAL TONE DETECTION

Case	frequency Hz	level (total)	twist*	duration	validity
1	2110 and 2745	-2.2 dBV	7dB	90 ms	valid
2	2150 and 2780	-2.2 dBV	7dB	110 ms	valid
3	2110 and 2745	-40 dBV	7dB	90 ms	valid
4	2150 and 2780	-40 dBV	7dB	110 ms	valid

Table 1- 7b. Idle State Tone Alert Signal - Dual Tone Detection

*The twist should be tested in both directions.

4.2 Datalink Layer

TE shall recognise V.23 FSK signalling.

4.2.1 Channel Seizure

Using test circuit 1, valid CLI signals are sent to the TE with the channel seizure set to 96 bits. The TE shall correctly detect this condition.

4.2.2 Mark Signal

Using test circuit 1, valid CLI signals are sent to the TE with the mark signal set to 55 bits. The TE shall correctly detect this condition.

4.2.3 Checksum

Using test circuit 1, valid CLI signals are sent to the TE with:

A correct Checksum .The TE shall detect this as a valid condition.

An incorrect Checksum. The TE shall correctly detect this as a NOT valid condition.

A message with the Checksum missing. The TE shall correctly detect this as a NOT valid condition.

4.3 TE Operation

4.3.1 DC wetting pulse

Using test circuit 1 with R set to 1400 Ohms, valid CLI signals are sent to the TE.

The TE shall draw a DC current, commencing 20 +/- 5 ms after the end of the idle state tone alert signal (see Fig 1- 1.).

The current shall rise to a minimum of 25 mA and maintain that current for a total time of not less than 5 ms.(see Fig 1- 3.)

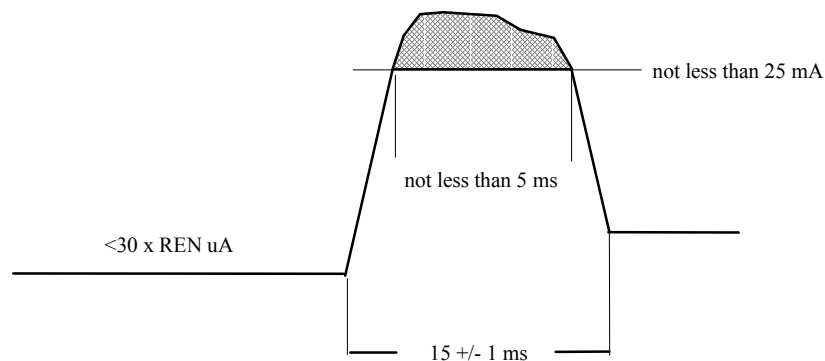

Fig 1- 3.

4.3.2 AC Load

Use the test circuit of Figure A.4.1.2 of ETS300 001: 1992. Tables 4.1.2 and A.4.1.2 ETS300 001: 1992 (Test Circuit 2. of this document), apply with the following changes to the UK entry:

- (a) the range of feed current I_f shall be replaced by one value which is the maximum current drawn by the TE in accordance with 5.1.3.
- (b) the reference impedance Z_r and impedance Z_g shall both be replaced by Z_{SS} .
- (c) if required the TE may be connected via a socket as described in ETS300 001: 1992 section 8.2.

4.3.3 DC Load

Using test circuit 1, valid CLI signals are sent to the TE. The TE may apply a load to draw DC current up to 0.5 mA. The DC load shall be applied and removed at the same time as the AC load impedance.

4.3.4 Detection of end of Signalling and removal of Loads

Using Test Circuit 1, valid CLI signals are sent to the TE and terminated prematurely during the V.23 signalling. The TE shall remove all loads within 1 second of termination of the V.23 signalling and revert to the idle state.

Test Circuits

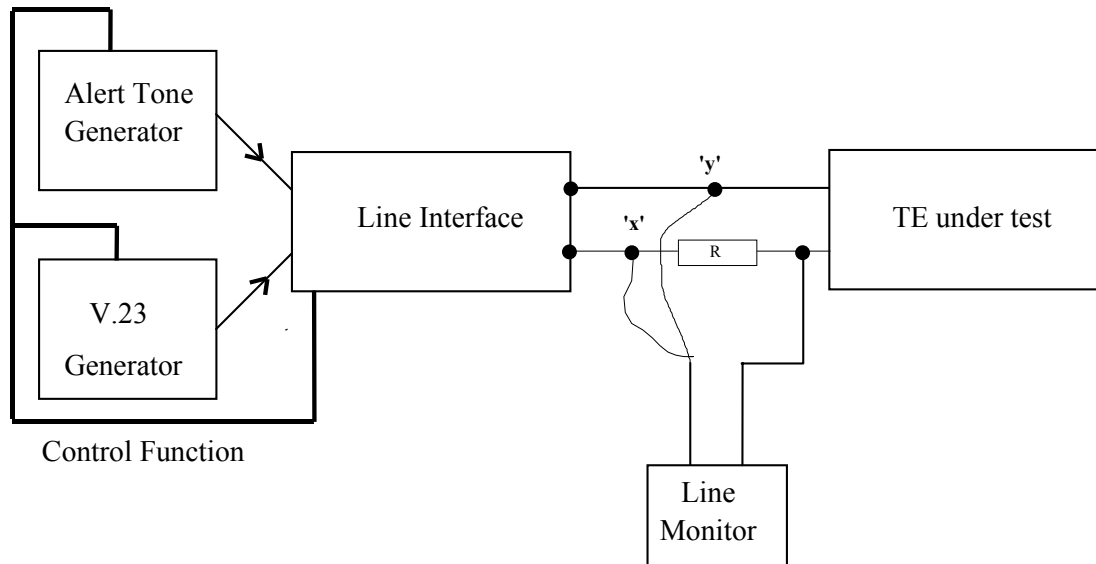

Test circuit 1.

The above circuit provides the ability to generate CLI signals controllable over the range of values required by the tests of clause 4. It could be represented by the following modules.

Line Interface. This module is capable of providing line feed over the voltage and current ranges specified and reversing line polarity as shown in Table 1- 2.

Idle State Tone Alert Generator. This module is capable of generating the Idle State Tone Alert signals over the range of parameters in clause 4.1.3. It is able to generate either single tone and dual tones as required.

It is capable of producing one or more interfering tones with total power of 20 dB below the signal tones.

V.23 Signal Generator. This module is capable of generating V.23 signals over the range shown in clause 4.2. Datalink Layer.

Line Monitor. This module (typically an oscilloscope) is capable of detecting line changes and measuring timings of conditions applied by the TE as in clause 5. It may be connected either in position 'x' or 'y' as shown in Test circuit 1.

Test circuit 2. This is the circuit ETS 300 001:1992 clause 4.1.2 Input impedance of TE in loop condition. The values shown in ETS 300 001:1992 Table 4.1.2 shall be replaced by the values in clause 3.2 of this standard.

~END OF PART 1~

PART 2: LOOP STATE SIGNALLING

1 Network Connection

1.1 Loop State

Before the receipt of CLI Signals the TE shall present a loop state as described in ETS 300 001:1992 para 1.4.5.2.

2 SIGNALLING

2.1 Physical Layer

The TE shall detect CLI signals and operate as shown in Fig 2-1. and Table 2-1.

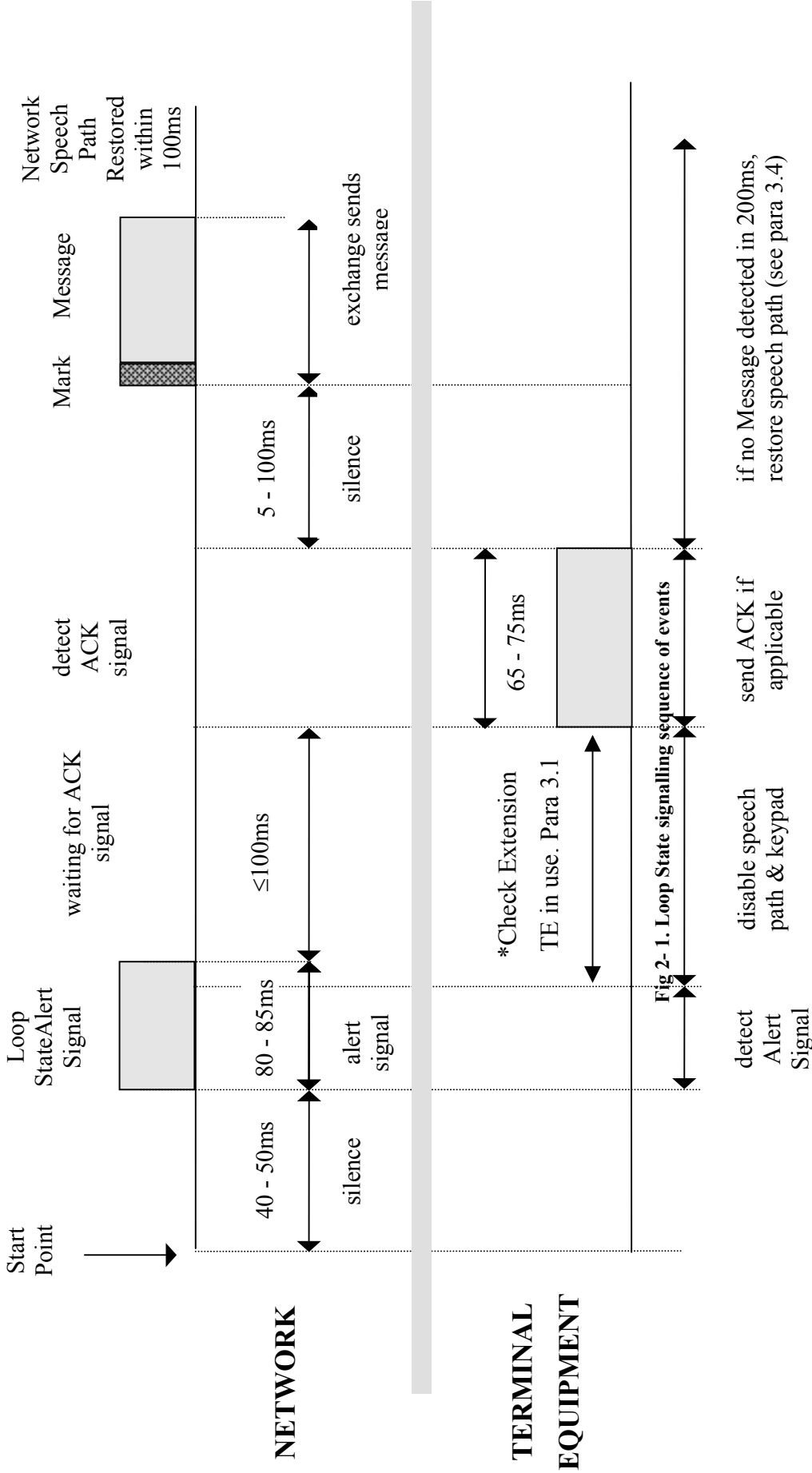

Network	TE	reference
start point		2.1.1
transmission to distant customer disabled in both directions		2.1.1
send alert signal		2.1.2
	detect alert signal	3.1
	check no other TE in loop state	3.1
	disable local speech path in both directions	3.1
	send Acknowledge (ACK)	3.3
detect ACK		
send Message		
	receive Message	3.4
restore transmission		
	restore local speech path	3.4

Table 2- 1. CLI Loop State

2.1.1 The Start Point

The Start Point will be service dependent and will be specified in the appropriate Application Layer description in the relevant Annex to this document. As an example, for Call Waiting with Caller Display the start point is the end of the first tone ON portion of the audible Call Waiting Indication.

At this point the exchange will have already disabled the speech path to the distant customer in both directions of transmission.

2.1.2 Loop State Tone Alert Signal

The exchange will wait 40 to 50ms from the Start Point, then send the Alert signal.

TE must recognise the Loop State Tone Alert Signal by the detection of **both** frequencies together.

The Loop State Tone Alert signal is:

Frequencies	2130 Hz and 2750 Hz \pm 0.6%
Received signal level	-8 dBV to -40 dBV
Signal Level differential	up to 7 dB
AC and DC Load Impedance	DC - ETS 300 001:1992 Section 2.3 Alternatively NV NTR Issue 2 ^[4] AC - ETS 300 001:1992 Section 4.1.2 Alternatively NV NTR Issue 2 section 5
Unwanted Signals	Total power of extraneous signals in the voice band (300-3400 Hz) is at least 20 dB below the signal levels.
Duration	80 to 85ms

Table 2- 2. Received Characteristics of Loop State Alert Signal

2.2 Datalink Layer(Basic Mode)

TE shall recognise V.23 FSK signalling.

The received V.23 FSK signalling may vary between the values shown in Table 2- 3.

Mark (logic 1)frequency	1280.5 Hz	1319.5 Hz
Space (logic 0)frequency	2069.5 Hz	2131.5 Hz
Mark level	-40dBV	-14 dBV
Space level	-36 dBV	-8 dBV
Total power of extraneous signals in the voice band (300-3400 Hz).	-64 dBV	-34 dBV
Transmission rate	1188 baud	1212 baud

Table 2- 3. Received Characteristics of V.23 Signals

2.2.1 Channel Seizure

NOTE: Channel seizure is not sent for Loop State signalling.

2.2.2 Mark Signal

The TE shall detect the Mark signal.

2.2.3 Checksum

TE shall always check the checksum byte. If the checksum is in error, then the signalling packet shall be treated as erroneous in its entirety and discarded. The TE shall not assume

even that the message type byte is correct, and so NO assumption can be made as to the purpose of the message.

Note. If the Checksum is in error it may be useful to display a suitable message.

3 TE Operation

Throughout the Loop State signalling the TE shall maintain terminating conditions compatible with the interface characteristics described in SIN 351 ^[5].

The TE shall operate in the following way.

3.1 Detection of Alert Signal

TE shall detect the Alert signal and respond by disabling the MF signalling sender (keypad) and the local speech path in both directions.

Note: TE may first check that no other TE, on the same line, are in the Loop State (off-hook). It is recommended that detection of other TE in the Loop State (off-hook) is achieved by monitoring of current or voltage changes on the line. TE should **not** detect other TE in the Loop State by entering the Idle State (on-hook) momentarily and checking line voltage as this could destroy the integrity of immediately subsequent in-band signals. It may be convenient for TE to constantly monitor the line for other TE in the Loop State (off-hook).

3.2 Analysis of Alert Signal

TE shall recognise the Alert signal by the detection of both frequencies together. The validation time shall not be less than 70ms.

The Acknowledge (ACK) signal must not be sent before the Alert signal has ceased but must commence within 100ms of the end of the Alert signal.

It is recommended that the Loop State Alert signal detection performance be optimised by carrying out conformance tests based on the requirements described in Bellcore document SR-TSV-002476 ^[6].

It is recommended that the Loop State Alert signal “talk-off” and “talk-down” (i.e. false detection of Alert signal due to the presence of speech and missed Alert signals in the presence of speech) performance be optimised by carrying out conformance tests based on the requirements described in Bellcore document SR-TSV-002476 .

The test requirements to ensure compliance with the above recommendations are detailed in section 4 of the Bellcore Special Report SR-3004 ^[7].

It is recommended that the manufacturer consider a range of suppliers and design options for Alert Signal detection circuit elements in order to optimise the performance of loop state Alert Signal detection.

3.3 Acknowledge Signal (ACK)

The TE shall detect the Tone Alert and respond by sending an ACK signal.

If other TE in the Loop State (see 3.1) are detected then the either:

- the ACK shall not be sent or,
- the ACK signal may still be sent and the message received. **However**, if a subsequent Checksum error is detected (see 2.2.3 and 4.2.) it is recommended that a message is displayed to advise the user of the probable source (e.g. “extension equipment in use”) or,

- It is recommended that TE offer both options, configurable by the user.

If ACK is sent while other TE are in the Loop State users may receive a burst of noise caused by the data transmitted from the Network. If ACK is not sent while other TE are in the Loop State data will not be sent from the Network. It is important that user instructions clearly explain that this is not an error. If an option is offered, the instructions should explain how to configure the TE to send or withhold ACK in these conditions. It is recommended that if the ACK signal is not sent then the reason is notified on the display to the user.

The ACK signal is the Dual Tone Multi Frequency (DTMF) Digit 'D' (Reference 3) and shall be 65 - 75ms in duration.

Care should be taken to minimise the impact of any line transients caused by application of the DTMF sender to line. In order to allow maximum time for line conditions to stabilise, after changes in AC and DC loads are applied, the following actions are recommended:

- The DTMF sender should be applied at the earliest opportunity before sending the ACK.
- It is advisable to delay the ACK as long as possible whilst still commencing within 100ms.
- The MF tone waveform should meet the requirements of BS6305:1992 ^[8] paragraphs 4.4.3.3 and 4.4.3.4. These requirements deal with the transient voltages, rise and fall of the tone waveform.

3.4 Detection of message

The exchange will detect the ACK and respond by sending the Message. The Message will commence between 5 and 100ms from the end of the ACK.

If the TE does not detect the beginning of the Message within 200ms of the end of sending the ACK it will abandon the signalling and re-enable the MF signalling sender (keypad) and local speech path.

The TE shall receive the data and operate as described in appropriate Annexes to this document.

After the complete Message has been sent the exchange will restore speech transmission within 100ms.

TE shall restore the keypad and local speech path after the message has been completed.

TE shall respond to valid conditions by receiving data as described in Annexes to this document.

3.5 User Information

In addition to the user information called up by other standards, there shall be advice about multiple installation of TE and interpretation of error messages.

Where TE is designed to work with Caller Display in both the Idle State (Part 1 of this SIN) and also in the Loop State (Part 2) the user information should make this clear in a prominent position.

4 Loop State Electrical And Signalling Tests

Valid CLI test messages, providing facilities described in Annexes to SIN227 and of types which the TE is designed to receive, shall be sent to the TE with each of the conditions of 4.1 applied. In each case only the parameter concerned shall be varied with all other parameters set to centre (nominal) specification unless stated otherwise. The signalling sequence and parameters are shown in Fig 2- 1. and Table 2- 1.

TE shall respond to valid conditions by operating as described in clauses 4.1 to 4.3.

4.1 Timing, ACK And Muting

4.1.1 The TE shall respond correctly when the timing from the ‘Start Point’ to the beginning of the Loop State Tone Alert is set first to 40ms and then 50ms.

4.1.2 The TE shall send an ACK in response to the Loop State Tone Alert within 100ms of receipt.

4.1.3 The TE shall not recognise a Loop State Tone Alert:

(a) lasting less than 70ms.

(b) consisting of only the 2130Hz tone.

(c) consisting of only the 2750Hz tone

4.1.4 The TE shall not send an ACK until after the Loop State Tone Alert has ceased.

4.1.5 The ACK shall be between 65ms and 75ms and shall be the Dual Tone Multi Frequency (DTMF) Digit ‘D’, ITU-T Recommendation Q.23 ^[9].

4.1.6 The ACK shall meet the requirements of BS6305:1992 paragraphs 4.4.3.3 and 4.4.3.4 (Reference 4).

4.1.7 The TE shall respond correctly when the timing from the receipt of the ACK to the beginning of the Mark + Message is set first to 5ms and then 100ms.

4.1.8 The TE shall disable the local speech path in both directions and the keypad on receipt of the Loop State Tone Alert.

4.1.9 The TE shall restore the restore the local speech path and MF signalling sender (keypad) within 100ms after the end of the Message.

4.1.10 The TE shall restore the speech path and MF signalling sender (keypad) if the Mark + Message is not received within 200ms.

4.2 Datalink Layer

4.2.1 The TE shall respond correctly when the Mark is set to 55ms.

4.2.3 Checksum

Valid CLI signals are sent to the TE with:

A correct Checksum .The TE shall detect this as a valid condition.

An incorrect Checksum. The TE shall correctly detect this as a NOT valid condition.

A message with the Checksum missing. The TE shall correctly detect this as a NOT valid condition.

4.3 Detection Of Other TE In The Loop State

TE shall **not** detect other TE in the Loop State by entering the Idle State (on-hook) momentarily and checking line voltage. During the signalling tests the line state shall be monitored to ensure that such 'line breaks' are not introduced.

~END OF PART 2~

History

Issue 1	August 1994	First Issued.
Issue 2	November 1996	Second Edition.
Issue 2.1	June 2001	Editorial Changes.
Issue 2.2	November 2002	Editorial Changes.
Issue 2.3	January 2004	Terminal Equipment approval clause removed, information available via www.sinet.bt.com Useful Contacts page.

WE WOULD BE GRATEFUL IF YOU WOULD SPEND A FEW MINUTES TO COMPLETE AN ONLINE CUSTOMER SATISFACTION FORM AT [HTTP://WWW.SINET.BT.COM/HAPPY.HTM](http://www.sinet.bt.com/happy.htm)

~END~

ANNEX A Calling Line Identification Presentation (CLIP)

The format for CLI messages is show in Fig A- 1.

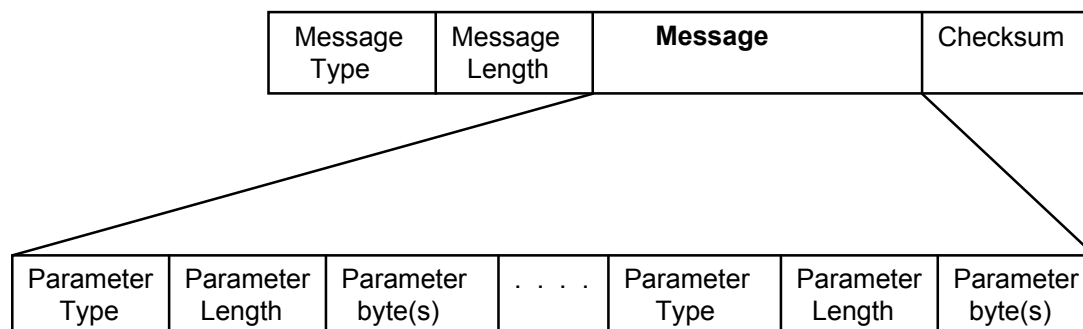

Fig A- 1. CLI message structure

TE intended to recognise CLI messages shall process data as specified in this annex. Full details of the message structure are contained in SIN227.

A1 Valid CLIP message

A call containing a CLIP message with the structure shown in Table A- 2. shall be sent to the TE. The call type parameter, if present will always be sent first. Other parameters may be sent in any order. Each of the parameters of A1.1 to A1.10 shall be varied in turn. The TE shall respond by correctly processing the message.

A1.1 Message Type

TE shall respond to the message type code by correctly processing the remainder of the message. Other codes shall cause the TE to ignore the remainder of the message.

The Message Type for CLIP is binary 10000000, indicating “Supplementary Information Message”. Other message types may be used for other purposes.

There are eight parameter types associated with CLIP:

Parameter Type value	Parameter name
00010001	Call Type
00000001	Time & date
00000010	<i>Calling</i> line directory number (DN)
00000011	<i>Called</i> directory number
00000100	Reason for absence of DN
00000111	Caller name/Text
00001000	Reason for absence of name
00010011	Network Message System Status

Table A- 1. CLIP parameters

The following parameters must be interpreted:

- Call Type
- Time & date
- Calling line directory number
- Reason for absence of DN

Optionally, TE may also interpret these parameters:

- Caller Name/Text
- Called directory number
- Reason for absence of Caller Name
- Network Message System Status

A1.2 Message Length

The longest CLIP message (excluding DATALINK layer information) is currently 64 bytes. Additional CLIP parameters may be added later that might lengthen the message to about 90 bytes. However, any new parameters will be sent after the ones mentioned here. If (to minimise buffer length) the TE chooses not to store bytes after the 64th, then the TE must still process received bytes for checksum purposes. All bytes in the message are included in the checksum.

A1.3 Call Type

TE shall recognise this parameter. If Call Type is not sent the TE shall treat the message as Voice Type.

If the Call Type is not recognised by the TE then Call Types with values of 127 (binary 01111111) and below may displayed and stored.

Messages with an unrecognised Call Type of 128 (binary 10000000) and above shall be ignored.

A1.4 Time & Date

If calls are stored (that is, stored for display after the end of the call) then the Time & date parameter should be logged with the calling number/name.

This parameter may also be used to set clocks, provided the Call Type is 127 (binary 01111111) or below, or is not specified.

A1.5 Calling Line Directory Number

In order to unambiguously represent a UK phone number, at least the last 11 significant digits must be stored. Non-numeric punctuation characters space and “-” may be included. For example, a telephone number might be sent as:

0	1	2	3	4	-	5	6		7	8		9	0
---	---	---	---	---	---	---	---	--	---	---	--	---	---

or:

0	1	2	3	-	4	5	6		7	8	9	0
---	---	---	---	---	---	---	---	--	---	---	---	---

These examples are illustrative: the grouping of digits may differ from that shown, and may vary from call to call.

In order to allow for international numbers it is recommended that the display should be capable of storing at least 22 characters, including punctuation. The number may be displayed on a display narrower than 22 digits provided that the display can be scrolled to display at least 22 digits. It is recommended that the display width be at least 14 characters wide. Where the number exceeds the storage capacity of the TE (for example an international number) then some indication that the number is truncated should be given, and any call-back capability suppressed on incomplete numbers.

The TE should not reformat the number for display (for example by addition or removal of punctuation). However, if the TE makes use of the number to make a return call, then punctuation must be deleted in determining the digits to dial.

The number delivered will not include any access number that may be required when dialling a return call. If the TE requires a processable form of the number (for example for a return call, or to enter the number in a local repertory store), then all non-numeric digits should be removed.

A return call should not be attempted where the number is incomplete, indicated by the character “-” as the last character of the Calling Line Directory Number parameter.

A1.6 Reason for Absence of Calling Line Number (DN)

The TE must interpret Reason for Absence of DN. The reason may be displayed as received in the first byte of the parameter (the single ASCII characters “P” or “O”). Alternatively (and better) they may be translated to the messages “Number Withheld” and “Number Unavailable” as appropriate.

A1.7 Called Directory Number

The format of this parameter is identical to that of Calling Line Directory Number, and should be treated accordingly. Processing of Called number is optional, and this parameter will not be sent at the launch of the CLIP service.

A1.8 Caller Name/Text

If Caller Name/Text is processed then the TE shall be capable of storing at least 16 characters but preferably 20. The information may be displayed on a narrower display if scrolling is provided such that all 20 characters can be displayed. It is recommended that the display should be at least 16 characters wide. The TE may map lower case letters to upper case (where the display cannot display lower case letters), but this is not recommended.

Where the Caller Name/Text is absent, then if the TE has a local directory with name and number, it may attempt to look up the caller number, and use this locally-programmed name for display. Where both a Caller Name/text and locally programmed name are available, it is recommended that the locally programmed name should be displayed.

A1.9 Reason for Absence of Caller Name

If Caller Name/Text is processed then the TE must interpret Reason for Absence of Caller Name. The reason may be displayed as received in the first byte of the parameter (the single ASCII characters “P” or “O”). Alternatively (and better) they may be translated to the messages “Name Withheld”, and “Name unavailable” as appropriate.

A1.10 Network Message System Status

The parameter byte for Network Message System Status indicates when messages are waiting in a message system such as BT's *Call Minder™*. A value of zero means no messages waiting, a value of 1 means one or more messages waiting.

A1.11 CLIP Message Encoding

The following sequence signifies the CLIP message:

Message type	CLIP
Call type	VOICE
Time:	10:30 a.m.
Date:	15th March
Calling Number:	0351-3210
Caller name:	A-Test

Table A- 2. Valid CLIP message

This is coded as in **Table A- 3. Valid CLIP message encoding**

message type	clip	10000000
message length	43 bytes	00101011
parameter type	call type	00010001
parameter length	1 byte	00000001
parameter	voice	00000001
parameter type	time & date	00000001
parameter length	8 bytes	00001000
parameter	0	00110000
	3	00110011
	1	00110001
	5	00110101
	1	00110001
	0	00110000
	3	00110011
	0	00110000
parameter type	calling line number (dn)	00000010
parameter length	9 bytes	00001001
parameter	0	00110000
	3	00110011
	5	00110101
	1	00110001
	-	00101101
	3	00110011
	2	00110010
	1	00110001
	0	00110000

Table A- 3. Valid CLIP message encoding

Table A- 3. Valid CLIP message encoding (continued)

parameter type	called line number	00000011
parameter length	9 bytes	00001001
parameter	0	00110000
	1	00110001
	2	00110010
	3	00110011
	-	00101101
	4	00110100
	5	00110101
	6	00110110
	7	00110111
parameter type	reason for absence of dn	not sent
parameter length		not sent
parameter		not sent
parameter type	caller name/text	00000111
parameter length	6 bytes	00000110
parameter	A	01000001
	-	00101101
	T	01010100
	e	01100101
	s	01110011
	t	01110100
parameter type	reason for absence of name	not sent
parameter length		not sent
parameter		not sent
parameter type	network message system status	not sent
parameter length		not sent
parameter		not sent

~END OF ANNEX A~

ANNEX B CALLING LINE IDENTITY PRESENTATION WITH CALL WAITING

B1 Overview

Calling Line Identity Presentation (CLIP) can be combined with Call Waiting (CW) to provide delivery of the identity of the caller when a second telephone call arrives during an existing call. The service will initially offer caller number^{iv} using signalling in the Loop State mode.

When CLIP and Call Waiting are provided on a line and are active then a CLIP message will be delivered with every incoming call.

Where Call Waiting is de-activated and therefore no second call is presented, CLIP in the Idle State will not be affected.

Where the caller's name or number is not delivered, then the reason for non-delivery will be indicated (currently there are two possibilities: name or number not available, and name or number withheld by the caller). Text messages generated by the network may also be sent.

In addition to caller identity, the CLIP Service also delivers the time and date, and (optionally) an indication of call type. The time may be used to set clocks in TE. For other services the time and date may not be the current time and date.

DISPLAY CALLER WITHHELD

Callers may have legitimate reasons for withholding their CLI from the called party. At the same time as the introduction of the Caller Display Service, BT introduced a corresponding service that allows callers to withhold CLI on a per call basis. This service to withhold CLI is activated by the caller dialling the prefix digits 141 in front of the number to be called. Use of this 141 prefix will result in the call being marked "private" within the network. The "CLI Withheld" parameter will be sent as a reason for the absence of CLI as the caller display message.

As an extension to the 141 service, in some instances it will be necessary to provide the CLI Withheld Service for all calls from a particular line. In this case CLI will be withheld for all calls and there will be no need to prefix each call with 141. CLI can be sent on a per call basis in this instance by dialling the prefix 1470.

141 AND THE IMPACT ON TE

It is important that TE should support the prefix 141 for customers wishing to withhold their CLI. TE suppliers should note that chargeable calls could start with the prefix 141. This could affect payphones, call-logging equipment, barring equipment and possibly private network numbering schemes.

The digits 141 will be treated as a service activation code and absorbed at the local exchange. There will be no second dial tone or confirmation to the caller after 141. The caller will be able to dial the rest of the call in the normal way immediately after 141. Onwards routing on the basis of the remaining digits will take place as usual and provide access to other operators using their normal access codes.

^{iv} The service may be enhanced later to deliver caller name.

MALICIOUS CALL TRACE

The use of 141 will not prevent operation of the malicious call trace capability of the network. The malicious call trace is a network operator function.

B2 Message Format

This section does not define how TE should process, store or display information contained within the messages.

The signalling system is the same as that for Calling Line Identification Presentation (CLIP) described in Annex A of this document.

B3 CLIP+CW Message Timing

The Start Point for Call Waiting with Caller Display is the end of the first tone ON portion of the audible Call Waiting Indication.

Loop State CLIP signalling will be sent once (and only once) following the receipt of the Acknowledge signal from the TE. (see Figure 3, SIN 227).

B4 Requirements for CLIP Parameters

This subsection identifies some requirements for sending CLIP parameters. These are the same as that for Calling Line Identification Presentation (CLIP) described in Annex A of this document.

B5 Message Length

This is the same as that for Calling Line Identification Presentation (CLIP) described in Annex A of this document.

B6 Message Structure Example

This is the same as that for Calling Line Identification Presentation (CLIP) described in Annex A of this document.

~END OF ANNEX B~